

CASE STUDY



The Load-Bearing System from the Perspective of Sustainable Building

Osama A. B. Hassan^{1,*} and Hamid Rezaei²

¹Department of Science and Technology, Linköping University, Sweden

²Peab Grundläggning AB, Sweden

Abstract: The building sector has a great potential to achieve goals for sustainable development by promoting environmental quality, economic effectiveness, and social improvement. One aspect that can possibly be considered in this context is the design of the building structure. The purpose of this case study is to investigate how the choice of a load-bearing system of building can affect the amount of concrete and steel reinforcement used in the foundation and its impact on the economy and environment. An alternative structural system of an existing building is proposed. The load-bearing frame walls and spread concrete foundations under walls are replaced by load-bearing timber columns that are placed on separate concrete footing pads. The results show that the amount of concrete and steel in the proposed system has considerably been decreased compared to the reference building. Consequently, this results in minimizing the construction costs as well as the resulting emissions of carbon dioxide into the environment. This case study reviews practical engineering design aspects that can be used by structural and construction engineers to help achieve sustainability goals of the built environment.

Keywords: sustainability, load-bearing systems, architectural design, climate change, cost estimate

1. Introduction

Sustainable development is a function of two major components, ecological and human [1]. Ozone depletion, climate change, depletion of aquifers, species extinction, soil and water pollution, and air pollution are among the clear signs of environmental distress and unsustainable development. The main threats to sustainable development are the emissions of greenhouse gases from human activity, which results in global warming. Climate change is expected to cause more extreme weather events with severe implications for infrastructure, health, and nature. Sustainable projects and optimal strategies for development necessitate answering four fundamental questions: “why unsustainable development occurs,” “what is sustainability?,” “how can it be measured?,” and “which factors affect it?” [2]. Consequently, sustainability is a multidimensional model that is characterized by multifaceted and mutual interrelations between technical, ecological, and socio-economic systems.

Sustainability can be developed to comprise many arenas in the society. The construction sector is one of the essential parts of modern society. Designing and establishing sustainable buildings will consequently be beneficial to endorsing an effective economy, green communities, and effective natural resource management [3].

In general, typical building constructions can have a considerable impact on the environment, resource use, and human health and productivity. According to preliminarily estimates, buildings may account for more than 30% of total final energy consumption [3]. According to Statista [4], the European Union (EU-27) has been

responsible for approximately 18% of global carbon dioxide emissions produced since the start of the industrial revolution. In addition, the construction sector is estimated to provide up to 10% of employment at the national level and produce up to 15% of GDP [4]. Furthermore, the EU aims to be climate neutral by 2050 with zero greenhouse gas emissions [5]. Subsequently, the building sector now faces new challenges in achieving the environmental climate goal.

One way to achieve sustainability in construction technology is to integrate the environmental and economic consequences of the building elements with the structural design of the building. Building production and construction design should therefore be re-engineered in a creative way to satisfy the requirements of sustainable development, especially with regard to reducing carbon dioxide emissions.

Building materials that can have a relatively large climate impact are concrete and steel. Concrete reinforced with steel can make up to 50% of the total emissions during the construction process [6]. In concrete, cement is an important part and almost all carbon dioxide emissions from concrete come from the production of cement [7]. Consequently, the building design should be re-engineered so that the amount of concrete and steel is reduced in an effective way. This reduction will be compensated by using environmentally friendly and renewable materials such as wood, especially in lands that are rich in forests. Wood has a relatively low climate impact and can bind carbon dioxide for a long time, which reduces carbon dioxide emissions, thereby facilitating achievement of climate goals [8].

The greatest climate impact of concrete occurs during the production of cement clinker, which is an intermediate product in the production of the binder. Cement is usually made by crushing

*Corresponding author: Osama A. B. Hassan, Department of Science and Technology, Linköping University, Sweden. Email: osama.hassan@liu.se

limestone and clay which is then heated to a temperature of 1400 °C. Ninety percent of the carbon dioxide emissions from concrete come from the cement clinker. The other 10% comes from transport, manufacturing of concrete and concrete products, and other sub-materials [7]. Additionally, manufacturing of steel to reinforce concrete is also very energy-intensive process and for every ton of reinforcement 720 kg CO_{2e} is released [9].

The purpose of this paper is to investigate how the choice of a load-bearing system, in practice, can affect the amount of concrete and steel reinforcement used in the foundation and its impact on the economy and environment. In this case study, the structural system of an existing building is transformed from load-bearing walls on spread foundations to load-bearing columns on footing pads.

A number of studies related to the evaluation of building sustainability are published. Erdenekhuu et al. [10] suggested a procedure based on Monte Carlo simulations to assess the critical risk factors related to construction activities. Soust-Verdaguer et al. [11] studied the construction project with respect to cost estimates and proposed a method to align cost estimation data structure with building information modeling considering life cycle sustainability assessment. Tsimplokoukou et al. [12] suggested that by considering the environmental issues in the early design stage can facilitate achieving building sustainability. These studies however are not directly related to structural design with respect to building sustainability. Franzitta et al. [13] compared the energy and economic performances of two buildings: a real residential bioclimatic building and an imaginary residential building supposed having the same geographical location. The purpose is to investigate how the bioclimatic principles can reduce energy demands and CO₂ emissions in the building sector. Pombo et al. [14] reviewed methods for housing retrofits to conduct an effective assessment of energy-efficiency measures and greenhouse gas emissions. These methods include the thermal insulation of the envelope, replacement of windows, and air tightness of the building. However, the question that can be arisen here is how redesigning the load-bearing system of the building can affect greenhouse gas emissions.

Hooton [15] investigated the emission of CO₂ from concrete structures. To reduce carbon footprint of concrete, the author suggested that the amount of Portland cement clinker must be decreased. However, this issue should be harmonized with durability of concrete so as not to affect durability of concrete in the long term. In the same context, Ayeni et al. [16] investigated the performance of a Nigerian metakaolin-based geopolymer as a sustainable material alternative to Portland cement to reduce the global CO₂ emissions. Stanaszek-Tomal [17] examined bacterial self-healing concrete

Figure 1
Overview picture of reference building



Figure 2
Placement of load-bearing walls

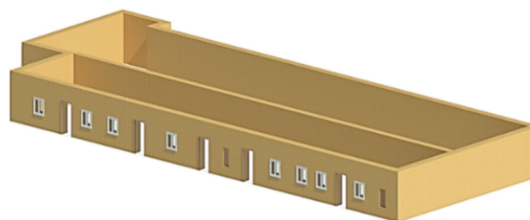

reduces costs in terms of detection of damage and maintenance of concrete structures and performs somewhat better than the Portland cement with respect to carbonation process. However, it is unknown how this type of concrete can work in the load-bearing system of a real building. Further review on low carbon concrete can be found in Nazari and Sanjayan [18].

Hassan et al. [8] studied sustainability in structural design by comparing concrete columns and timber columns. Other similar studies can be found in Hassan et al. [8]. This study thus attempts to fill the literature gap left by previous studies by redesigning a real building to serve the sustainability principle by minimizing the construction costs as well as the resulting emissions of carbon dioxide into the environment.

2. Reference Building

The reference building is an existing one-storey residential building built in Sweden¹ (see Figure 1). The structural system consists of load-bearing timber wall framing and prefabricated wooden trusses (see Figure 2). The soil under the construction is an excavated surface layer packed full of gravelly sand, and under these layers the ground consists of much firmly stored soil. The basic foundation of the building is spread footing (reinforced concrete ground slab/beam on the ground, cast-in-situ), which supports the load-bearing walls (thickness 344 mm) (see Figures 3–5). In Figure 4, the total thickness of the exterior wall is 344 mm, the thickness of concrete slab is 180 mm, and dimensions of the edge beam are 500 mm × 400 mm. In Figure 5, the total thickness of the internal wall is 120 mm, the thickness of concrete slab is 180 mm, and dimensions of the ground beam are 500 mm × 280 mm. The concrete used has strength class C45/C55 and exposure class XC4. The steel grade for the reinforcement used in the study is B500B.

For the edge foundation, steel bars with diameter $\phi 10$ (distance between bars 400 mm) and diameter $\phi 12$ were used, as well as reinforcement steel mesh ($\phi 6$). For the internal foundation, it used $\phi 12$ bars in the lower edge. The timber trusses were placed at a distance of 1.2 m in accordance with the structural requirements (see also Figure 6).

3. Proposed Structural System

A new structural system in the form of load-bearing columns and foundations pads (Figures 6–7) is proposed instead of a frame system with load-bearing walls and spread footings under walls, as in the reference building. In this system, the timber joists rest on the timber columns and support timber trusses.

In order to take into account the structural requirements of the building [19,20] as well as the architectural design, the

¹Sjötörps Bygg. (n.d.). Om Sjötörps Bygg. Retrieved from: <https://sjotorpshus.se/sida.php?sida=12&rubrik=Om+Sj%C3%B6törps+Bygg>

Figure 3
Placement of spread foundation under load-bearing walls

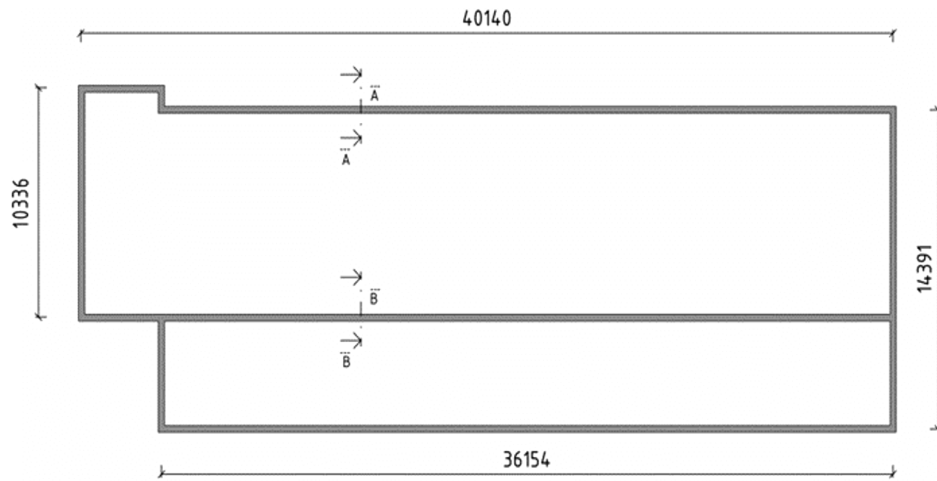

Figure 4
Edge foundation underneath exterior walls, section A-A

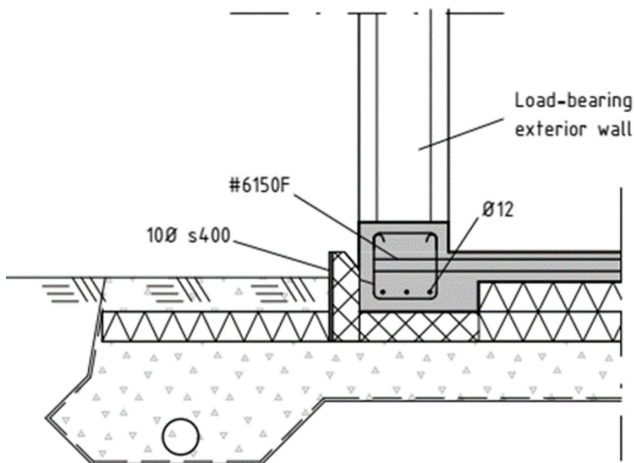

Figure 6
An overview of suggested structure

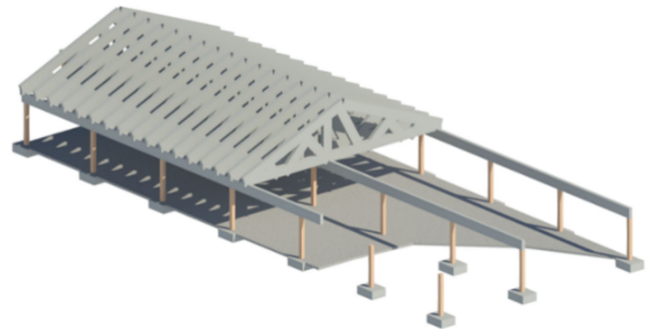

Figure 5
Internal foundation underneath internal walls, section B-B

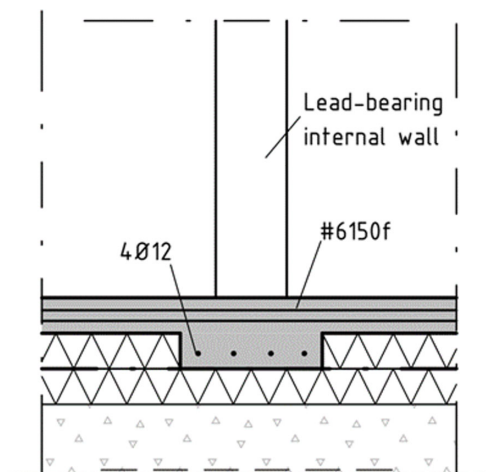
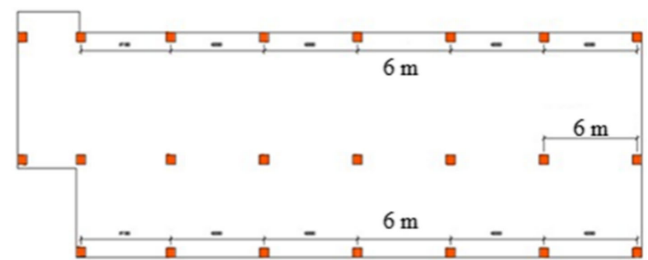

Figure 7
Placement of load-bearing columns



following aspects are defined. The glulam columns have a cross-sectional area of 220 mm × 220 mm, a length of 2636 mm, and strength class CE L40c. They are placed in three rows parallel to the long side of the house at a distance of 6 m from each other. The columns are placed on the same line as the load-bearing walls in the reference building so that the floor plan has as little change as possible compared to the reference building. Timber glulam joists with strength class CE L40c and a rectangular cross section of 220 mm × 450 mm are laid on the columns.

4. Methodology and Limitations

For the sake of comparison, the same roof construction is used, i.e., prefabricated wooden roof trusses with the same form as used in the reference building. To prevent lateral torsional buckling of the supporting beams, the trusses are placed at a distance of 1.2 m from each other and laid on the timber joists.

According to the geotechnical survey of the reference building, the soil’s bearing capacity under the building is between 100 kpa and 150 kpa. Therefore, the choice was made to spread the loads from columns to the ground via squared pad foundations with a cross section of 1100 mm × 1100 mm × 200 mm so that the pressure from the column would not exceed the bearing capacity of the soil under the building. Moreover, the squared pad foundation attends the punching process from pillar loads.

Wind load is the largest horizontal load that will affect the building. In this context, board walls in the façade were used between columns to stabilize the frame structure against the wind load. In the calculations, the wooden columns, wooden beams, and concrete base slab (isolated footing) are exposed to the largest design load (vertical and horizontal). The concrete quality in the footing is the same as the reference building with a strength class of C45/C55 and exposure class XC4. The steel grade for the reinforcement used in the foundation is B500B (as in the reference building) with diameter φ16 (Figure 8).

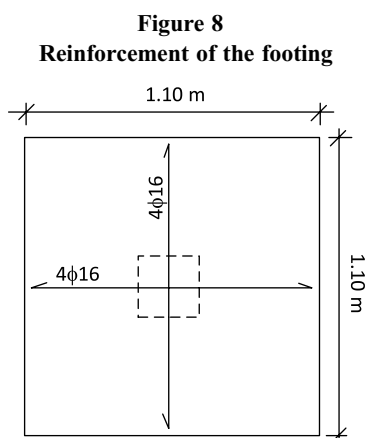

A structural check of the serviceability limit state and ultimate limit state is carried out according to the requirements stated in European Commission [19] and European Commission [20]. The calculations presented only consider the differences between the foundation of reference building and the proposed structural system assuming the same concrete slab on the floor for both cases.

With respect to economy and environment, only concrete and reinforcement (steel bars) of the foundation are considered for comparison between the two designs. The cost and carbon dioxide emissions of load-bearing timber columns, which is part of the suggested revised loading system, have not been considered in this study.

The calculation of materials costs and greenhouse gases – equivalents carbon oxides (CO_{2e}) – is determined. The study primarily considers embodied CO₂ as an indicator for assessing the environmental impact of the structure. For the environmental factor, the average emission of carbon dioxide to the air from concrete is set to 0.2 kg CO_{2e}/kg [8] and for steel 0.72 kg CO_{2e}/kg [9]. These values are based on approximative emissions from the complete life cycle of the construction material. Note, however, that these values

can vary depending on the production process. How much carbon dioxide concrete releases can be calculated using the following equation [8]:

$$CO_{2e} = X_c L b \rho h \tag{1}$$

where $X_c = 0.2$ kg CO_{2e}/kg, ρ is the concrete density ($\rho = 2400$ kg/m³), L is the length, b is the width, and h is the concrete plate’s thickness. For the steel reinforcement, the amount of carbon dioxide becomes

$$CO_{2e} = X_s W \tag{2}$$

where $X_s = 0.72$ kg CO_{2e}/kg and W is the quantity of all steel bars used in the foundation (kg).

In this study, the other factors that affect the climate and economy, such as transport and logistical aspects, have not been taken into account in the calculations. Moreover, for the same of comparison, only the material costs are considered. The cost of concrete formwork, assemblage, and other accompanying cost details to a finished construction is also not considered.

5. Results

Tables 1–2 show the results of cost estimates and emission of carbon dioxide for the reference building and the proposed new building. Note, however, that the cost of steel and concrete is estimated in accordance with prices found in the Swedish market in May 2022. This situation can typically vary from one country to another. The average exchange rate between the Swedish krona is 10 SEK = 1 dollar \$.

Table 1
Cost estimates of concrete and reinforcements.
SEK is Swedish kroner

Material	Indicator	Reference building	New building
Concrete	Quantity	18.247 m ³	5.566 m ³
	Amount	25000 SEK	7626 SEK
Steel bars	Quantity	936.1 kg	319.8 kg
	Amount	5234 SEK	1906 SEK
Total amount		30234 SEK	9532 SEK

Table 2
Emission of carbon dioxide equivalents (kg CO_{2e})

	Reference building	New building
Concrete	8758.6	2671.7
Steel	674.2	230.3
Total	9433	2902

6. Discussion

The results show that the amount of concrete in the proposed structural system decreased compared to the reference building from 18.247 m³ to 5.566 m³, a decrease of almost 70%. The amount of steel reinforcements decreased from 936.1 kg to 319.8 kg, a decrease of almost 65%. If one calculates the different quantities with the same price as in the reference building during the construction of the reference building, it will turn out that the

total for both concrete and reinforcement decreased from SEK 30234/m³ and kg to SEK 9532/m³ and kg, a decrease of almost 68%.

With regard to the environmental aspect, it is found that, if the reference building had been built with the proposed structural system, 6531 kg less carbon dioxide would have been released into the atmosphere instead. However, the actual amount of carbon dioxide emissions may be greater than what is in Table 2, because in this study, other factors that affect the climate such as transport and logistical aspects have not been taken into account.

The results suggest that most of the carbon emissions come from the concrete while reinforcement steel results in a very little fraction of the total amount (about 7%), which implies that the concrete is the main source of carbon emission for the studied case.

7. Concluding Remarks

The building sector has a great potential to achieve goals for sustainable development by promoting environmental quality, economic effectiveness, and social improvement. One aspect that can possibly be considered in this context is the design of the building structure.

This study investigates how the choice of a load-bearing system can affect the amount of concrete and steel reinforcement used in the foundation and its impact on the economy and environment. The results from the calculations of both serviceability limit state and ultimate strength state show that beams, columns, and foundation pads fulfill the requirements as stated in the Eurocode standards. The floor plan from the reference building is preserved as far as possible. When the existing floor plan in the reference building is compared with the new structural system, the living area and the net area become somewhat larger, since the load-bearing walls in the reference building are changed to non-load-bearing board walls that have, subsequently, a smaller thickness in the new frame system.

From a practical point of view, it is noteworthy to indicate that the constructor can sometimes use external concrete ground beams to connect the squared pad foundation and to support external and internal walls. This case will be most actual when the loads are large. In this study, such concrete beams are not used. If, on the other hand, such ground beams are to be included, then their impact on environment and economy need to be considered.

This study considered the embodied CO₂ as an indicator to assess the environmental impact of the structure. However, it can be interesting for future studies to expand the study to include the evaluation of embodied energy [MJ] values.

The estimated amounts that appear in the results may not be so large. But if one thinks that this result, with a 70% reduction in concrete, would be true of several new constructions, one could have saved many cubic meters of concrete. This could lead to less emissions of carbon dioxide into the atmosphere, without affecting the appearance of buildings or their conditions.

Technically, pad footings are generally suitable where the bearing capacity of the ground is sufficient at relatively shallow depths, as in this case study. However, these foundations may not be effective against differential settlements in relatively weak grounds, strong wind, and relatively large uplift forces. Moreover, spread (or strip) footings, in general, can be better than pad footing when dealing with closely spaced columns in multi-storey buildings. Consequently, the structural designer may carefully investigate the choice of foundation system to apply possible solutions for the sustainability.

The study did not consider the transport of the construction materials and related logistic issues although this matter can be important sometimes to the entire construction management. With respect to the amount of generated CO₂ emissions, it seems that

the fuel used in transport vehicles is decisive. A conventional diesel truck contributes more emissions than a hybrid truck does [21]. To reduce the environmental impact, it is necessary, subsequently, to follow the environmental guidelines in this respect. For instance, by using vehicles with an efficient use of resources (e.g., trucks that runs on electricity) the negative impact on the environment will be reduced.

This case study reviews practical engineering design aspects that can be used by structural and construction engineers to help achieve sustainability goals of the built environment.

The case study can also be used as a teaching exercise for engineering students.

Ethical Statement

This study does not contain any studies with human or animal subjects performed by any of the authors.

Conflicts of Interest

The authors declare that they have no conflicts of interest to this work.

Data Availability Statement

Data sharing not applicable – no new data generated.

Author Contribution Statement

Osama A. B. Hassan: Conceptualization, Methodology, Software, Validation, Formal analysis, Investigation, Data curation, Writing – original draft, Writing – review & editing, Visualization, Supervision, Project administration. **Hamid Rezaei:** Conceptualization, Methodology, Software, Validation, Formal analysis, Investigation, Data curation, Writing – original draft, Writing – review & editing, Visualization.

References

- [1] Milon, J. W., & Shogren, J. (1995). *Integrating economic and ecological indicators: Practical methods for environmental policy analysis*. UK: Bloomsbury Publishing.
- [2] Atkinson, G., Dubourg, R., Hamilton, K., Munasinghe, M., Pearce, D., & Young, C. (1999). *Measuring sustainable development: Macroeconomics and the environments*. UK: Edward Elgar Publishing.
- [3] Hassan, O. A. B. (2016). An integrated approach to assessing the sustainability of buildings. *Journal of Engineering, Design and Technology*, 14(4), 835–850. <https://doi.org/10.1108/JEDT-12-2014-0077>
- [4] Statista. (2024). *GHG emissions in the EU – Statistics & facts*. Retrieved from: <https://www.statista.com/topics/4958/emissions-in-the-european-union/>
- [5] European Commission. (n.d). *2050 Long-term strategy*. Retrieved from: https://climate.ec.europa.eu/eu-action/climate-strategies-targets/2050-long-term-strategy_en
- [6] IVA. (2014). *Klimatpåverkan från byggprocessen. A report from Royal Engineering Academy and building industries of Sweden*. Sweden: Royal Engineering Academy and Building Industries.
- [7] Svensk Betong. (2022). *Guidance Climate-improved concrete [Vägledning Klimatförbättrad betong]*. Retrieved from: <https://www.svenskbetong.se/component/edocman/?task=document.viewdoc&id=60&Itemid=>

- [8] Hassan, O. A. B., AA, N. E., & Abdulahad, G. (2022). A comparative study between glulam and concrete columns in view of design, economy and environment. *Case Studies in Construction Materials*, 16, e00966. <https://doi.org/10.1016/j.cscm.2022.e00966>
- [9] Özdemir, A., Günkaya, Z., Özkan, A., Ersen, O., Bilgiç, M., & Banar, M. (2018). Lifecycle assessment of steel rebar production with induction melting furnace: Case study in Turkey. *Journal of Hazardous, Toxic, and Radioactive Waste*, 22(2), 04017027. [https://doi.org/10.1061/\(ASCE\)HZ.2153-5515.0000385](https://doi.org/10.1061/(ASCE)HZ.2153-5515.0000385)
- [10] Erdenekhuu, N., Kocsi, B., & Máté, D. (2022). A risk-based analysis approach to sustainable construction by environmental impacts. *Energies*, 15(18), 6736. <https://doi.org/10.3390/en15186736>
- [11] Soust-Verdaguer, B., Bernardino Galeana, I., Llatas, C., Montes, M. V., Hoxha, E., & Passer, A. (2022). How to conduct consistent environmental, economic, and social assessment during the building design process. A BIM-based Life Cycle Sustainability Assessment method. *Journal of Building Engineering*, 45, 103516. <https://doi.org/10.1016/j.jobe.2021.103516>
- [12] Tsimplokoukou, K., Lamperti, M., & Negro, P. (2014). *Building design for safety and sustainability*. EUR – Scientific and Technical Research Series. 2014. <https://doi.org/10.2788/338223>
- [13] Franzitta, V., Milone, D., Trapanese, M., Viola, A., Di Dio, V., & Pitruzzella, S. (2013). Energy and economic comparison of different conditioning system among traditional and eco-sustainable building. *Applied Mechanics and Materials*, 394, 289–295. <https://doi.org/10.4028/www.scientific.net/AMM.394.289>
- [14] Pombo, O., Rivela, B., & Neila, J. (2016). The challenge of sustainable building renovation: Assessment of current criteria and future outlook. *Journal of Cleaner Production*, 123, 88–100. <https://doi.org/10.1016/j.jclepro.2015.06.137>
- [15] Hooton, R. D. (2021). Improving Performance and Reducing The CO₂ Footprint of Concrete Using Multiple Approaches. *Special Publication*, 349, 696–710. <https://doi.org/10.14359/51732782>
- [16] Ayeni, O., Onwualu, A. P., & Boakye, E. (2021). Characterization and mechanical performance of metakaolin-based geopolymer for sustainable building applications. *Construction and Building Materials*, 272, 121938. <https://doi.org/10.1016/j.conbuildmat.2020.121938>
- [17] Stanaszek-Tomal, E. (2020). Bacterial concrete as a sustainable building material? *Sustainability*, 12(2), 696. <https://doi.org/10.3390/su12020696>
- [18] Nazari, A., & Sanjayan, J. G. (2016). *Handbook of low carbon concrete*. Netherland: Elsevier.
- [19] European Commission. (2004). *Eurocode 2: Design of concrete structures – Part 1-1: General rules and rules for buildings*. Retrieved from: <https://eurocodes.jrc.ec.europa.eu/EN-Eurocodes/eurocode-2-design-concrete-structures>
- [20] European Commission. (2004). *Eurocode 5: Design of timber structures – Part 1-1: General – Common rules and rules for buildings*. Retrieved from: <https://eurocodes.jrc.ec.europa.eu/EN-Eurocodes/eurocode-5-design-timber-structures>
- [21] Bal, F., & Vleugel, J. (2017). The impact of hybrid engines on fuel consumption and emissions of heavy-duty trucks. *WIT Transactions on Ecology and the Environment*, 224, 203–212. <https://doi.org/10.2495/ESUS170191>

How to Cite: Hassan, O. A.B. & Rezaei, H. (2024). The Load-Bearing System from the Perspective of Sustainable Building. *Green and Low-Carbon Economy*. <https://doi.org/10.47852/bonviewGLCE42021717>